

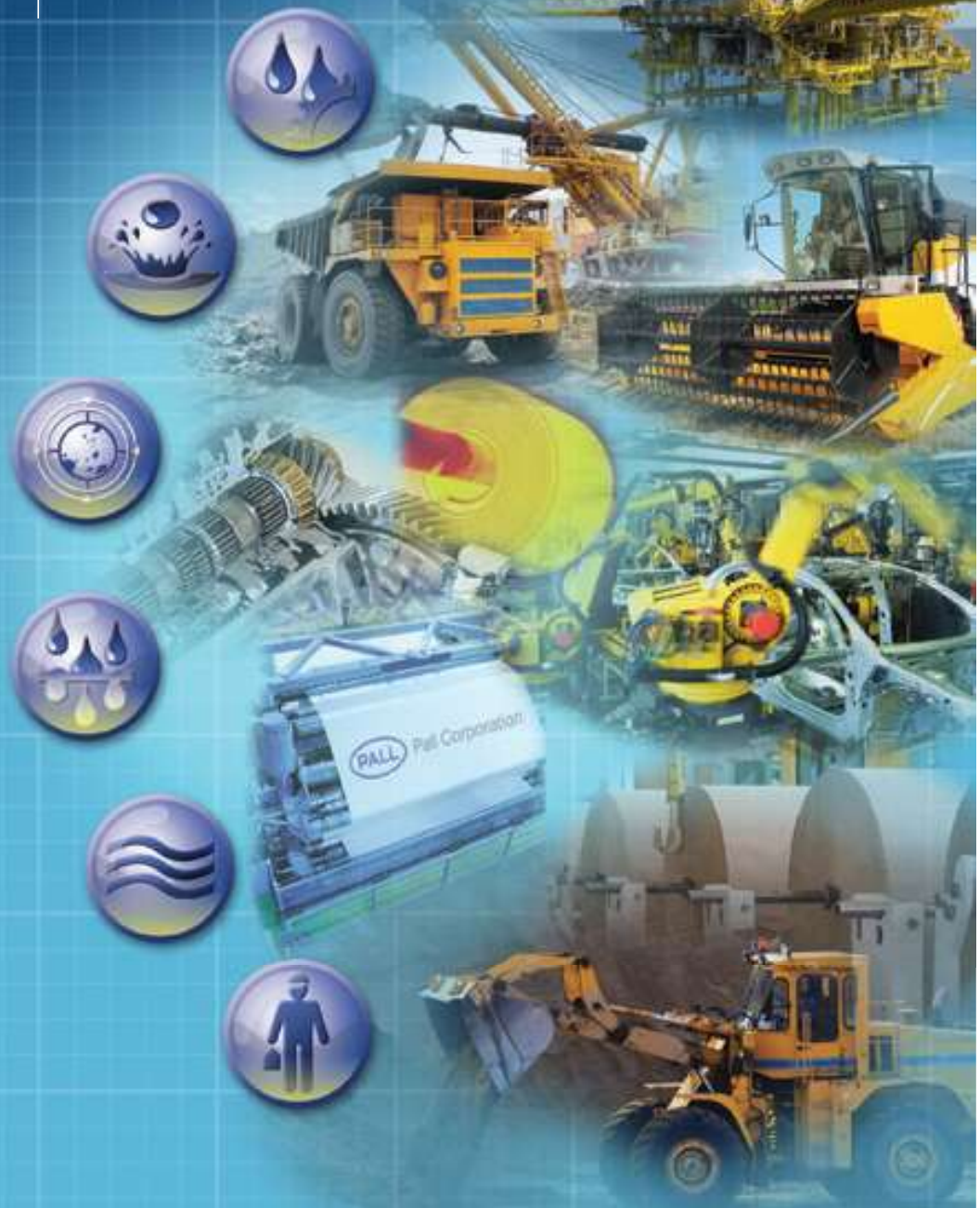

Pall Corporation

Filtration e-Book



Better Lives.
Better Planet.SM

Filtration. Separation. Solution.SM

Enabling a Greener Future

Businesses worldwide are challenged to conserve energy and resources while protecting the environment. Pall Corporation helps customers achieve these goals by providing leading-edge filtration and separation technologies that purify and conserve water, consume less energy, make alternative energy sources possible and practical and minimize emissions and waste. Our collective efforts are enabling a greener, safer, more sustainable future.

www.pall.com/green



***Better Lives.
Better Planet.SM***



Equipment Life Expectancy Factors

A study by Dr. E Rabinowicz at M.I.T. observed that 70% of component replacements or 'loss of usefulness' is due to surface degradation. In hydraulic and lubricating systems, 20% of these replacements result from corrosion with 50% resulting from mechanical wear.

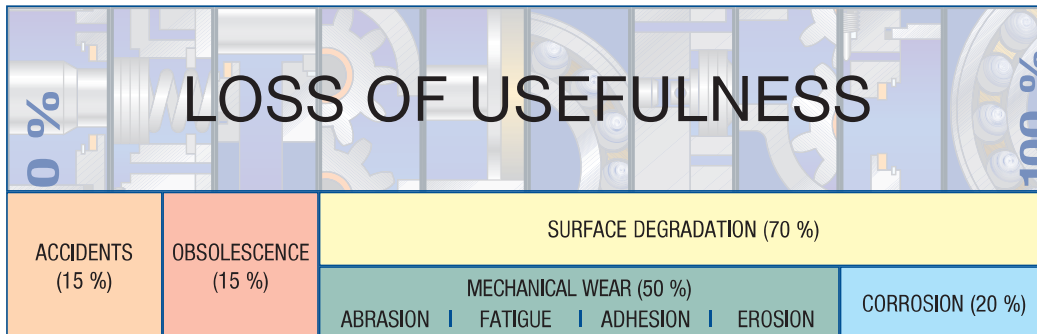

Presented at the American Society of Lubrication Engineers, Bearing Workshop.

Sources of Contamination

Built-in contaminants from components:

- Assembly of system
- Cylinders, fluids, hydraulic motors, hoses and pipes, pumps, reservoirs, valves, etc.

Generated contaminants:

- Operation of system
- Break-in of system
- Fluid breakdown

External ingress:

- Reservoir breathing
- Cylinder rod seals
- Bearing seals
- Component seals

Contaminants introduced during maintenance:

- Disassembly/assembly
- Make-up oil

The Micrometre "µm"

'Micron' = micrometre = µm

The micrometre is the standard for measuring particulate contaminants in lubricating and fluid power systems.

1 micron = 0.001 mm (0.000039 inch)

10 micron = 0.01 mm (0.0004 inch)

Smallest dot you can see with the naked eye = 40 µm

Thickness of a human hair = 75 µm

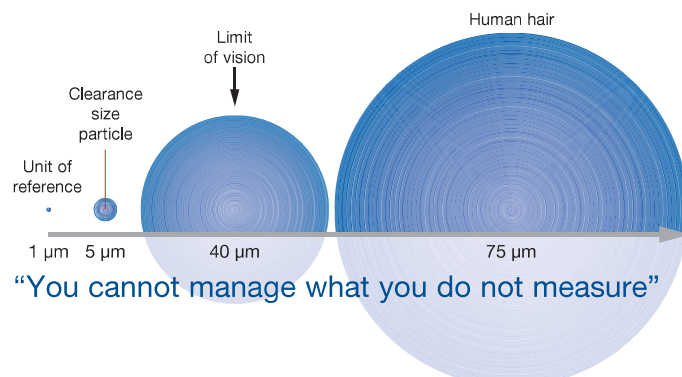

Mechanisms of Wear

Abrasive Wear

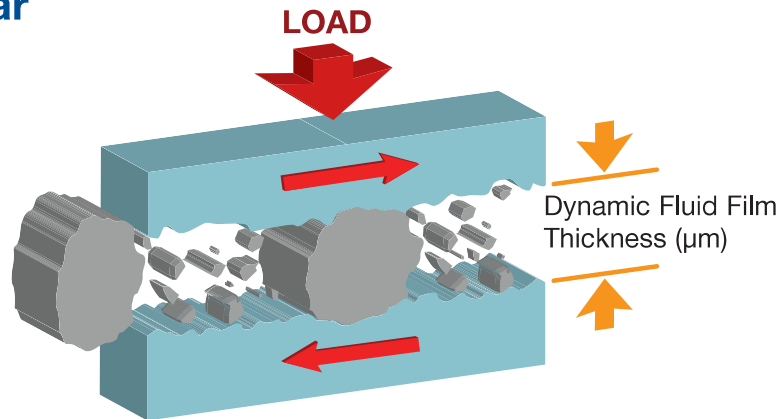

Abrasive Wear Effects:

- Dimensional changes
- Leakage
- Lower efficiency
- Generated wear: more wear

Typical components subjected to Abrasion:

- All hydraulic components: pumps, motors, spool valves and cylinders
- Hydraulic motors
- Journal bearings

Adhesive Wear

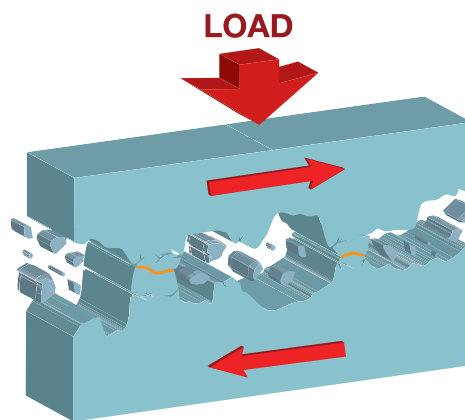

Surfaces weld and shear

Adhesive Wear Effects:

- Metal to metal points of contact
- 'Cold Welding'
- Adhesion and shearing

Typical components subjected to Adhesion:

- Hydraulic cylinders
- Ball bearings
- Journal bearings

Mechanisms of Wear (continued)

Fatigue Wear

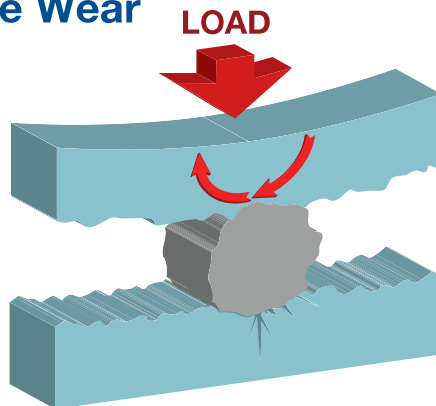

Particle caught, surfaces dented and cracking initiated

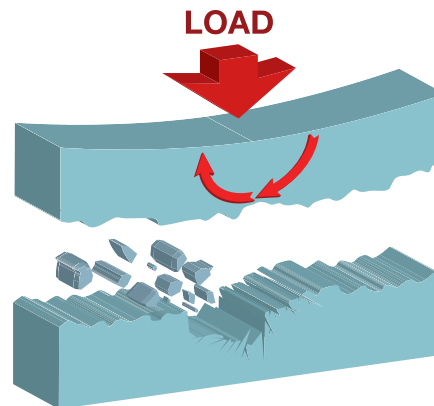

After 'N' fatigue cycles, cracking spreads, surface fails and particles are released

Fatigue Wear Effects:

- Leakage
- Deterioration of surface finish
- Cracks

Typical components subjected to Fatigue:

- Journal bearings
- Hydrostatic bearings
- Rolling element bearings
- Geared systems

Erosive Wear

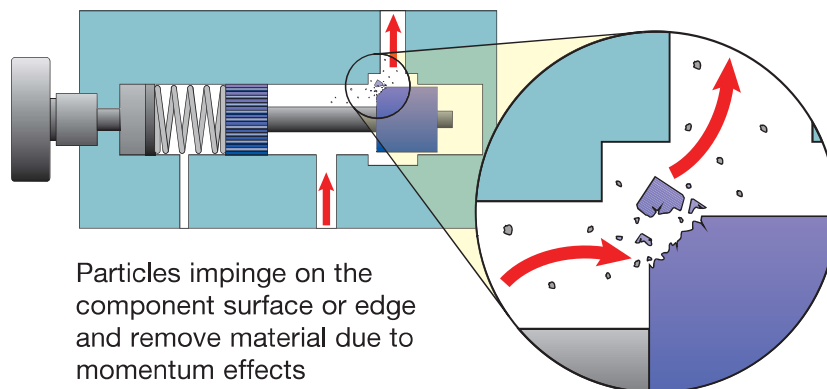

Particles impinge on the component surface or edge and remove material due to momentum effects

Erosive Wear Effects:

- Slow response
- Spool jamming/stiction
- Leakage
- Solenoid burnout

Typical components subjected to Erosion:

- Servo valves
- Proportional valves
- Directional control valves

Typical Dynamic (Operating) Clearances

Component	Details	Clearances
Valves	Servo	1 - 4 μm
	Proportional	1 - 6 μm
	Directional	2 - 8 μm
Variable Volume Piston Pumps	Piston to Bore	5 - 40 μm
	Valve Plate to Cylinder Block	0.5 - 5 μm
Vane Pumps	Tip to Case	0.5 - 1 μm
	Sides to Case	5 - 13 μm
Gear Pumps	Tooth Tip to Case	0.5 - 5 μm
	Tooth to Side Plate	0.5 - 5 μm
Ball Bearings	Film Thickness	0.1 - 0.7 μm
Roller Bearings	Film Thickness	0.4 - 1 μm
Journal Bearings	Film Thickness	0.5 - 125 μm
Seals	Seal and Shaft	0.05 - 0.5 μm
Gears	Mating Faces	0.1 - 1 μm

*Data from STLE Handbook on Lubrication & Tribology (1994)

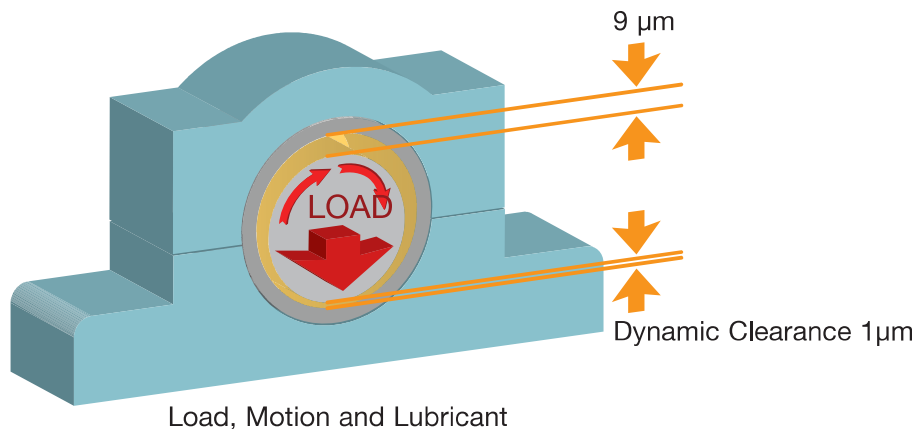

Fluid Analysis Methods for Particulate

Method	Units	Sampling	Benefits	Limitations
Optical Particle Count	Number/mL/ Cleanliness code	Off-line; Laboratory	Provides size distribution. Unaffected by fluid opacity, water and air in fluid sample	Sample preparation time
Automatic Particle Count (APC)	Number/mL/ Cleanliness code	Off-line; "Sip" from containers; On-line	Fast and repeatable	Sensitive to 'silts', water, air and gels
Filter / Mesh Blockage Technique	Cleanliness code	Off-line; "Sip" from containers; On-line	Not affected by the presence of air or free water in the fluid sample	Does not provide the size distribution of the contamination
Patch Test and Fluid Contamination Comparator	Visual comparison/ Cleanliness code	Off-line; Point of use	Rapid analysis of system fluid cleanliness levels in field. Helps to identify types of contamination	Provides approximate contamination levels
Ferrography	Scaled number of large/small particles	Off-line; Laboratory	Provides basic information on ferrous and magnetic particles	Low detection efficiency on non-magnetic particles e.g. brass, silica
Spectrometry	PPM	Off-line; Laboratory	Identifies and quantifies contaminant material	Limited detection above 5 µm
Gravimetric	mg/L	Off-line; Laboratory	Indicates total mass of contaminant	Cannot distinguish particle size. Not suitable for moderate to clean fluids. i.e. below ISO 18/16/13

Monitoring and Measurement Equipment

Automatic Particle Counters (APCs)

Automatic particle counters are the most common method used by industry for particulate contamination analysis.

Principle:

As a particle passes through the light beam, the light intensity received by the photo detector is reduced in proportion to the size of the particle.

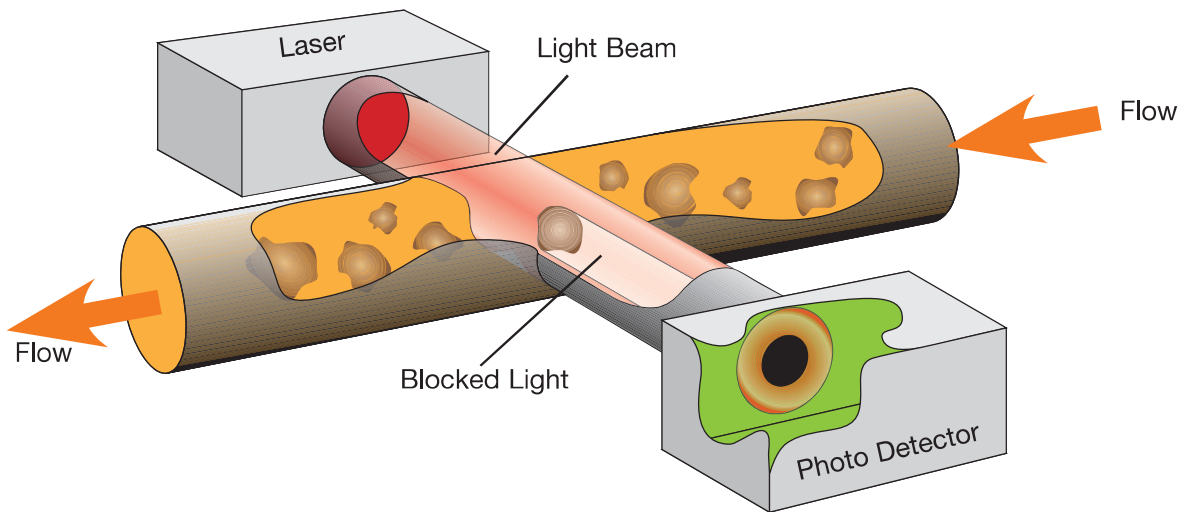

Mesh Blockage Devices

Filter/mesh blockage devices are an alternative to APCs, especially in conditions where the fluid is opaque or where free water or air is present in the fluid.

Principle:

Filter/mesh blockage devices determine particulate contamination levels by passing a specified flow of sample fluid through a series of calibrated mesh screens in a specified sequence. Pressure drop build-up (or flow degradation) is dependent on particulate contamination levels. The mesh is cleaned by backflushing.

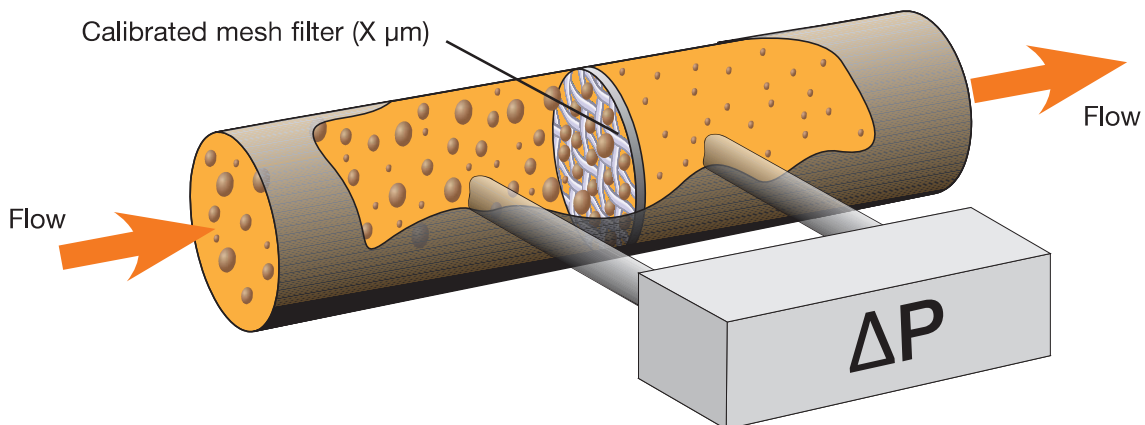

Monitoring and Measurement Equipment

Obtaining accurate and reliable fluid cleanliness data quickly in order to detect abnormal contamination is a key factor in ensuring the efficiency of industrial processes and reducing downtime.

Reliable Monitoring Solutions... ...Whatever the Conditions...Whatever the Fluid



Pall Cleanliness Monitors

Provide an accurate, reliable assessment of system fluid cleanliness

- Proven mesh blockage technology
- On-line and off-line modes of operation
- Results not affected by free water or undissolved air contamination
- Designed for use with dark or cloudy fluids
- ISO 4406 (3-digit Code), or AS4059 (NAS1638) data output
- Water sensor option

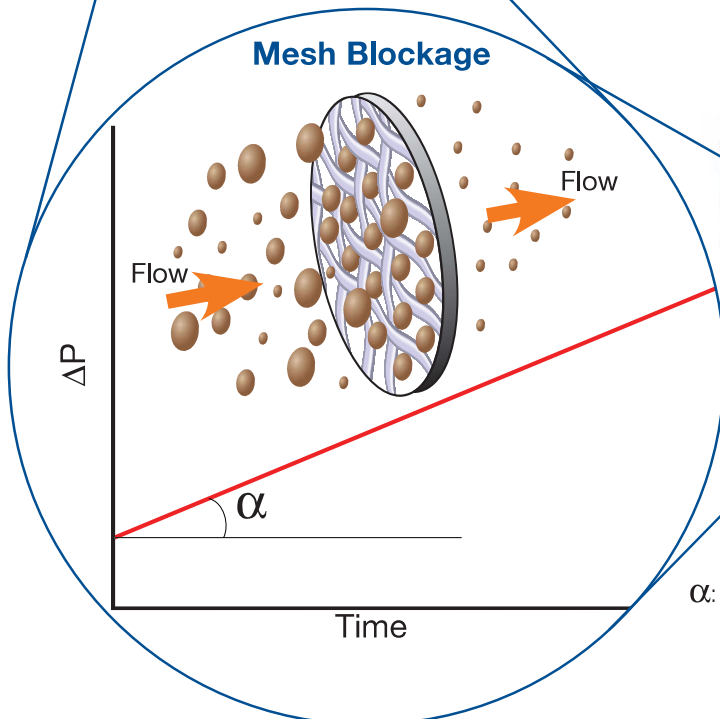

α : Rate of pressure drop increase (slope) across the mesh is based on the level of particulate contamination in the fluid (at constant flow and temperature)

Understanding the ISO 4406 Cleanliness Code

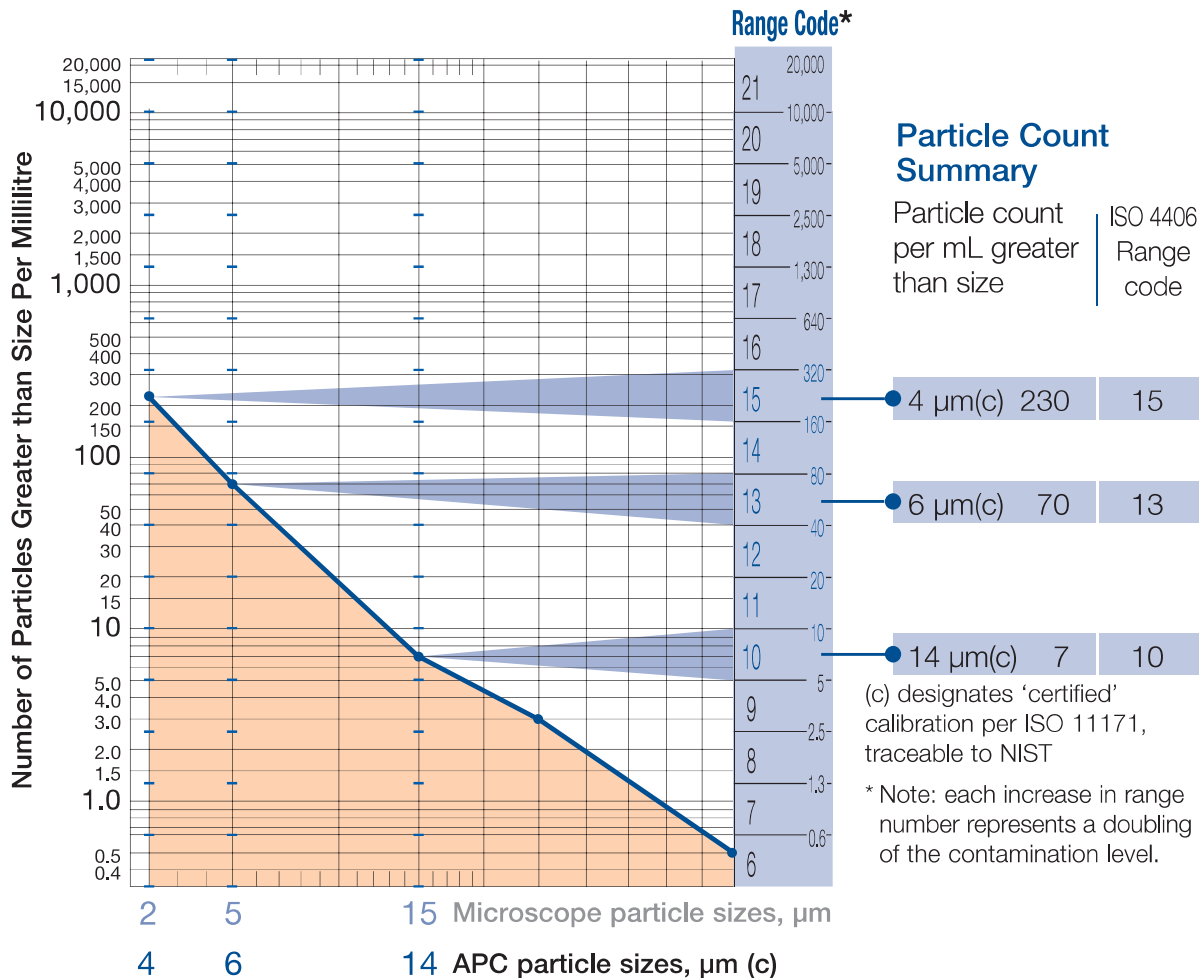

Fluid cleanliness levels found in modern hydraulic systems (typically ISO code <15/13/10 - see the area highlighted in orange) requires on-line monitoring.

The ISO Cleanliness code references the number of particles greater than 4, 6 and 14 µm(c) in one mL of sample fluid.

To determine the ISO Cleanliness code for a fluid, the results of particle counting are plotted on a graph. The corresponding range code, shown at the right of the graph, gives the cleanliness code number for each of the three particle sizes. For the example above the data becomes ISO 15/13/10. Where there is not a requirement for data at the first size or the technique used does not give this data e.g. microscope counts and PCM data, "-" is used, e.g. ISO -/13/10.

The ISO 4406 level for a system depends on the sensitivity of the system to contaminant and the level of reliability required by the user. A method for selecting the level for an individual system (called the "Required Cleanliness Level" or "RCL") is described on Pages 37 and 38.

ISO 4406 Cleanliness Code 13/11/09

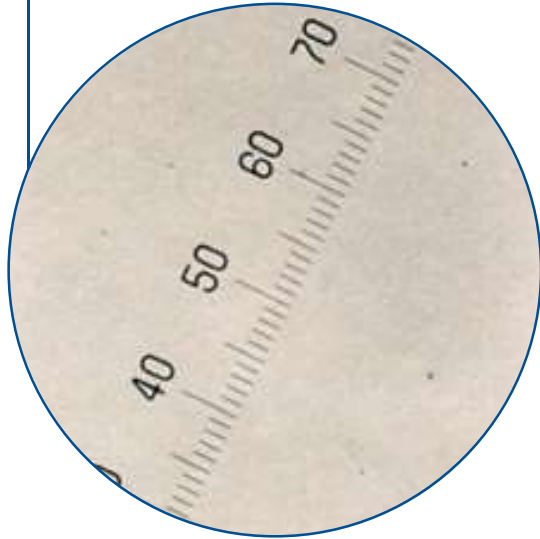

Sample Volume: 25 mL using Ø25 mm membrane filter or
100 mL using Ø47 mm membrane filter

Magnification: 100x

Scale: 1 division = 10 µm

Particle Count Summary

Size	Particle Count Range per mL	ISO 4406 Code	SAE AS4059 ^{1,2} (NAS1638)
>4 µm(c)	52	13	3A
>6 µm(c)	16	11	3B
>14 µm(c)	4	09	3C

Description

System with $\beta_{5(c)} > 1,000$ wear control filtration

Contaminants: Some black metal

ISO 4406 Cleanliness Code 19/16/11

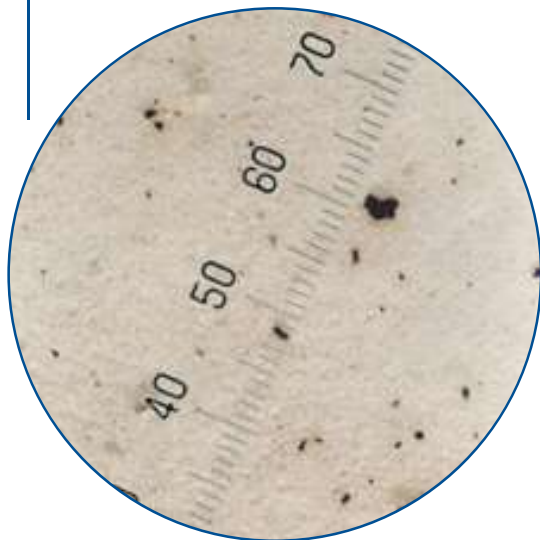

Sample Volume: 25 mL using Ø25 mm membrane filter or
100 mL using Ø47 mm membrane filter

Magnification: 100x

Scale: 1 division = 10 µm

Particle Count Summary

Size	Particle Count Range per mL	ISO 4406 Code	SAE AS4059 ^{1,2} (NAS1638)
>4 µm(c)	4,200	19	10A
>6 µm(c)	540	16	8B
>14 µm(c)	20	11	9C

Description

System with inadequate filtration.

Contaminants: Bright metal, Black metal, Silica, Plastics

¹AS4059 is based on 100 mL. ²AS4059 classes are for the 3 ISO 4406 size ranges

ISO 4406 Cleanliness Code 21/19/16

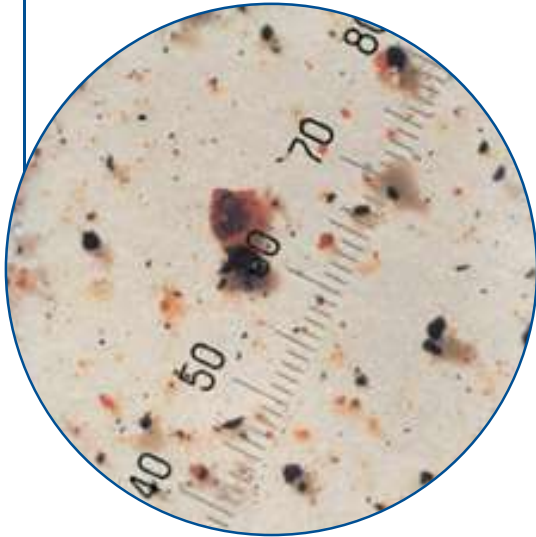

Sample Volume: 25 mL using Ø25 mm membrane filter or
100 mL using Ø47 mm membrane filter

Magnification: 100x

Scale: 1 division = 10 µm

Particle Count Summary

Size	Particle Count Range per mL	ISO 4406 Code	SAE AS4059 ^{1,2} (NAS1638)
>4 µm(c)	12,345	21	11A
>6 µm(c)	3,280	19	11B
>14 µm(c)	450	16	11C

Description

New oil from barrel

Contaminants: Silica, Black metal, Bright metal, Plastics

ISO 4406 Cleanliness Code 22/20/19

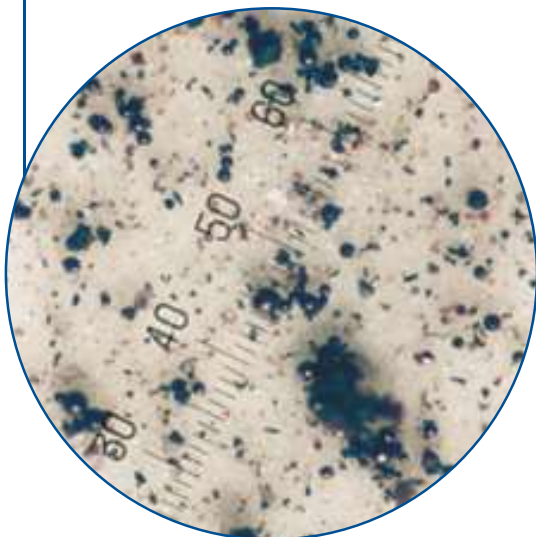

Sample Volume: 25 mL using Ø25 mm membrane filter or
100 mL using Ø47 mm membrane filter

Magnification: 100x

Scale: 1 division = 10 µm

Particle Count Summary

Size	Particle Count Range per mL	ISO 4406 Code	SAE AS4059 ^{1,2} (NAS1638)
>4 µm(c)	31,046	22	12A
>6 µm(c)	7,502	20	12B
>14 µm(c)	1,960	19	12C

Description

New system with built-in contaminants

Contaminants: Bright metal, Black metal, Rust, Silica, Plastics

¹AS4059 is based on 100 mL. ²AS4059 classes are for the 3 ISO 4406 size ranges

On-line Particulate Cleanliness Monitoring

We cannot control what we cannot measure

Modes of Analysis

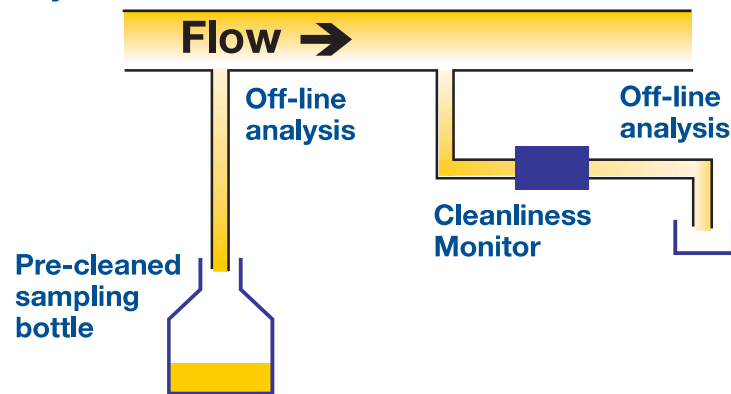

Comparison of on-line counting and off-line counting

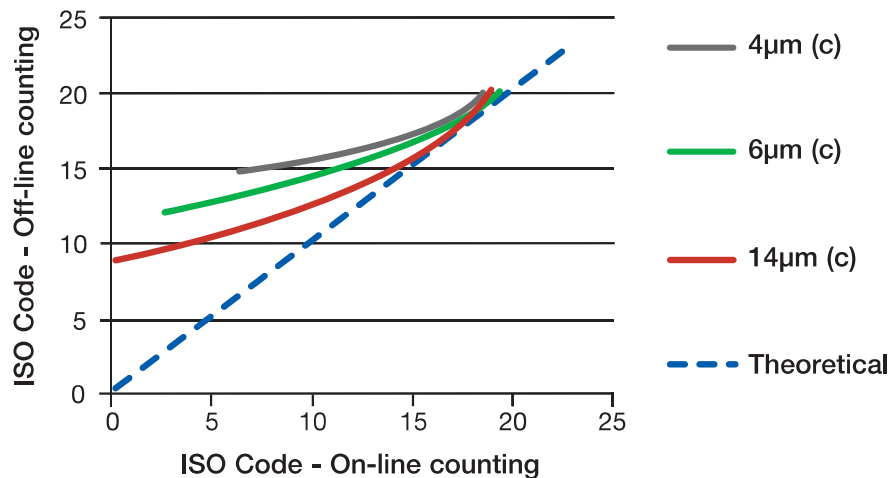

Source : Tampere University of Technology, Finland

At the higher contamination levels (higher ISO codes) there is little difference between the two modes of analysis, but as the oil gets cleaner, the level recorded by the off-line analysis inaccurately shows the oil to be dirtier compared to on-line analysis.

Factors influencing the accuracy of the off-line analysis:

- Introduction of environmental dirt into sample bottle
- Incorrect cleaning of sample bottle
- Inadequate flushing of sampling valve
- Effectiveness of sampling process

Fluid Sampling Procedure

Introduction

There are four methods for taking fluid samples, three for extracting samples and one for on-line analysis. Method 1 is the best choice followed by Method 2. Method 3 should only be used if there is no opportunity to take a line sample.

DO NOT obtain a sample from a reservoir drain valve. Always take the sample under the cleanest possible conditions and use pre-cleaned sample bottles.

If there are no line mounted samplers, fit a Pall sampling device to the Pall filter.

Method 1

Small ball valve with PTFE or similar seats, or a test point

1. Operate the system for at least 30 minutes prior to taking sample in order to distribute the particulate evenly.
2. Open the sampling valve and flush at least 1 litre of fluid through the valve. Do not close the valve after flushing.
3. When opening the sample bottle, be extremely careful not to contaminate it.
4. Half fill the bottle with system fluid, use this to rinse the inner surfaces and then discard.
5. Repeat step 4 a second time without closing the valve.
6. Collect sufficient fluid to fill 3/4 of bottle (to allow contents to be redistributed).
7. Cap the sample immediately and then close the sample valve.
Caution: Do not touch the valve while taking the sample.
8. Label the sample bottle with system details and enclose in a suitable container for transport.

Method 2

Valve of unknown contamination shedding capabilities

1. Operate the system for at least 30 minutes prior to taking sample in order to distribute particulate evenly.
2. Open the sampling valve and flush at least 3 to 4 Litres of fluid through the valve. (This is best accomplished by connecting the outlet of the valve back to the reservoir by using flexible tubing). Do not close the valve.
3. Having flushed the valve, remove the flexible tubing from the valve with the valve still open and fluid flowing. Remove the cap of the sample bottle and collect sample according to instructions 4 to 6 of Method 1.
4. Cap the sample immediately and then close the sample valve.
Caution: Do not touch the valve while taking the sample.
5. Label the sample bottle with system details and enclose in a suitable container for transport.

Fluid Sampling Procedure (continued)

Method 3

Sampling from Reservoirs and Bulk Containers

Applicable only if Methods 1 and 2 cannot be used

1. Operate the system for at least 30 minutes prior to taking sample in order to distribute the particles evenly.
2. Clean the area of entry to the reservoir where sample will be obtained.
3. Flush the hose of the vacuum sampling device with filtered (0.8 μm) solvent to remove contamination that may be present.
4. Attach a suitable sample bottle to the sampling device, carefully insert the hose into the reservoir so that it is mid-way into the fluid. Take care not to scrape the hose against the sides of the tank or baffles within the tank as contamination may be sucked into the hose.
5. Pull the plunger on the body of the sampling device to produce vacuum and half fill the bottle.
6. Unscrew bottle slightly to release vacuum, allowing hose to drain.
7. Flush the bottle by repeating steps 4 to 6 two or three times.
8. Collect sufficient fluid to 3/4 fill the sample bottle, release the vacuum and unscrew the sample bottle. Immediately recap and label the sample bottle.

Method 4

On-line Analysis

This procedure is for portable instruments that have to be connected to the system

1. Check that the sampling position satisfies the reason for sampling and the sampling valves/points complies with the requirements of Method 1;
2. Check that there is sufficient supply pressure to avoid instrument starvation or cavitation;
3. Operate the system for at least 30 min
4. Remove any covers, caps etc from the sampling position and, if practical, clean the exterior of the connection point with a clean solvent.
5. Carefully connect the instrument to the sampling point and minimise the generation of dirt
6. Operate the instrument in accordance with the manufacturer's instructions and flush the sampling lines and instrument with a suitable volume of fluid, as specified by the instrument manufacturer. If not a volume equivalent to 10 times the volume of the connection pipes and instrument is appropriate;
7. The analysis shall be continued until the data from successive samples is either:
 - a) within the limits set by the instrument manufacturer; or
 - b) the difference is less than 10 % at the minimum particle size being monitored if the required output is particle count; or
 - c) the same cleanliness code has been recorded.

Water Contamination in Oil

Water contamination in oil systems causes:

- Oil breakdown, such as additive precipitation and oil oxidation
- Reduced lubricating film thickness
- Accelerated metal surface fatigue
- Corrosion

Sources of water contamination:

- Heat exchanger leaks
- Seal leaks
- Condensation of humid air
- Inadequate reservoir covers
- Temperature reduction (causing dissolved water to turn into free water)
- Equipment cleaning via high pressure hose



Corrosion in the resevoir

Typical Water Saturation Curve

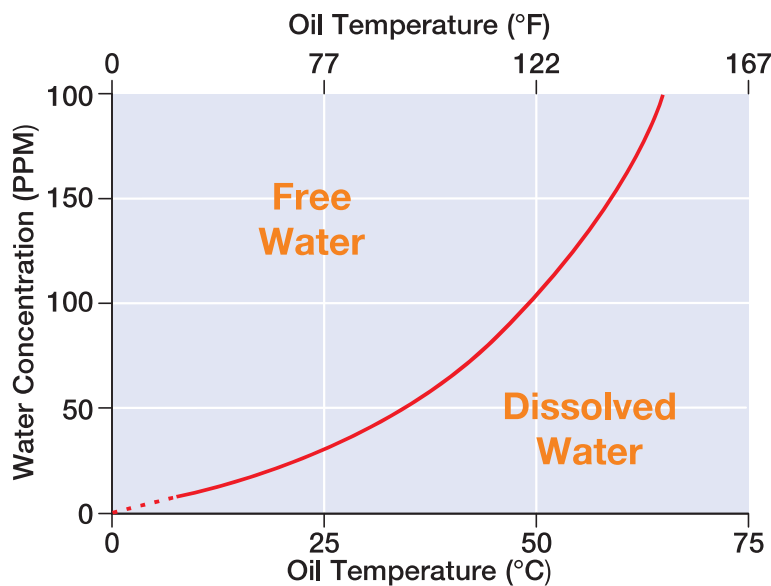

Ref: EPRI CS-4555 Turbine oil



Dissolved, emulsified and free water in oil

To minimize the harmful effects of free water, water concentration in oil should be kept as far below the oil saturation point as possible.

Water Concentration

10,000 PPM	1%
1,000 PPM	0.1%
100 PPM	0.01%

Water Content Analysis Methods

Method	Units	Benefits	Limitations
Crackle Test	None	Quick indicator of presence of free water	Does not permit detection below saturation
Chemical (Calcium hydride)	Percentage or PPM	A simple measurement of water content	Not very accurate for dissolved water
Distillation	Percentage	Unaffected by oil additives	Limited accuracy on dry oils
FTIR	Percentage or PPM	Quick and inexpensive	Accuracy does not permit detection below 0.1% (1,000 PPM)
Karl Fischer	Percentage or PPM	Accurate at detecting low levels of water (10 - 1,000 PPM)	Not suitable for high levels of water. Can be affected by additives
Capacitive Sensor (Water Sensor)	Percentage of saturation or PPM	Accurate at detecting dissolved water (0 - 100% of saturation)	Cannot measure water levels above saturation (100%)

Water Sensor Technology

Water contamination in fluids can cause numerous problems such as additive depletion, oil oxidation, corrosion, reduced lubricating film thickness, microbial growth, and reduction of dielectric strength. Water sensors incorporate a probe that can be directly immersed in the fluid to monitor dissolved water content and temperature.

A variety of water sensor models are available including explosion proof options. Contact Pall to determine the most appropriate model for your application.

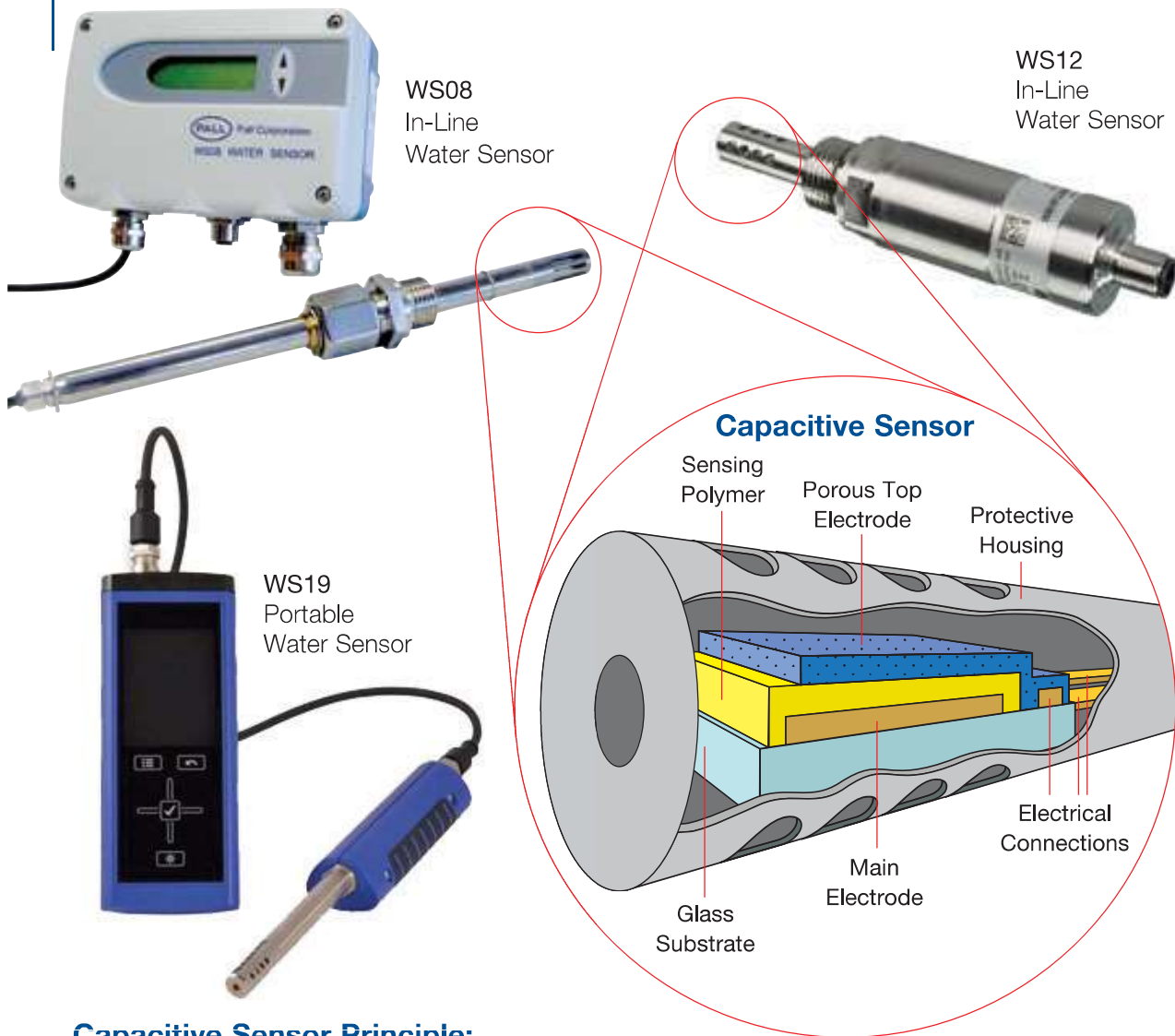

Capacitive Sensor Principle:

The electrical resistance of the dielectric polymer changes as the relative humidity changes. The water sensor probe is protected to avoid erratic results from solid contaminants settling on the porous top electrode.

Operating Principle of Pall Fluid Conditioning Purifiers

Principle: Mass transfer by evaporation under vacuum

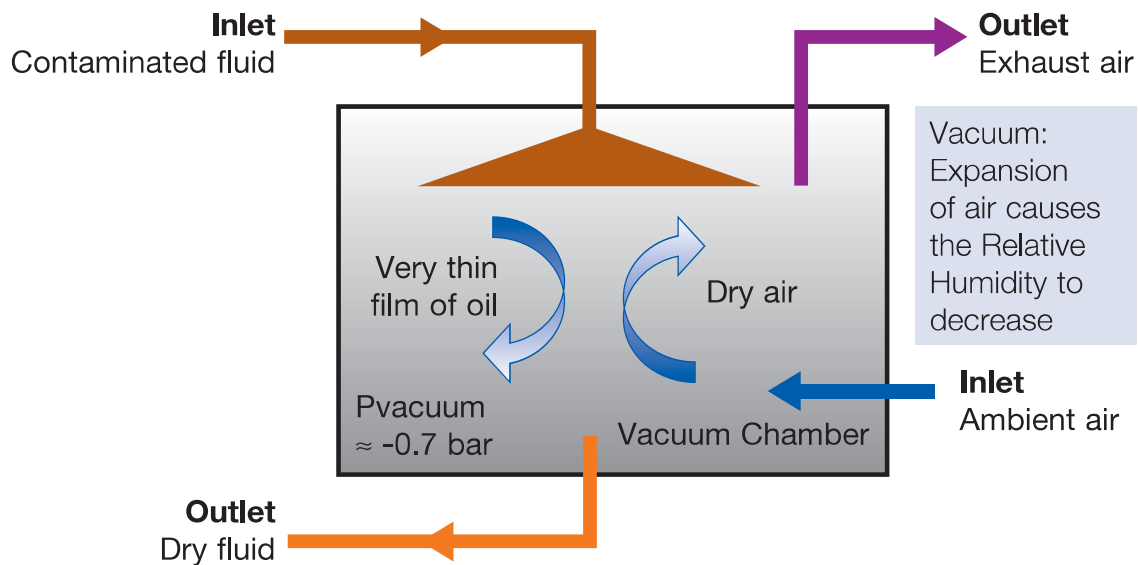

Removing free water is never enough!

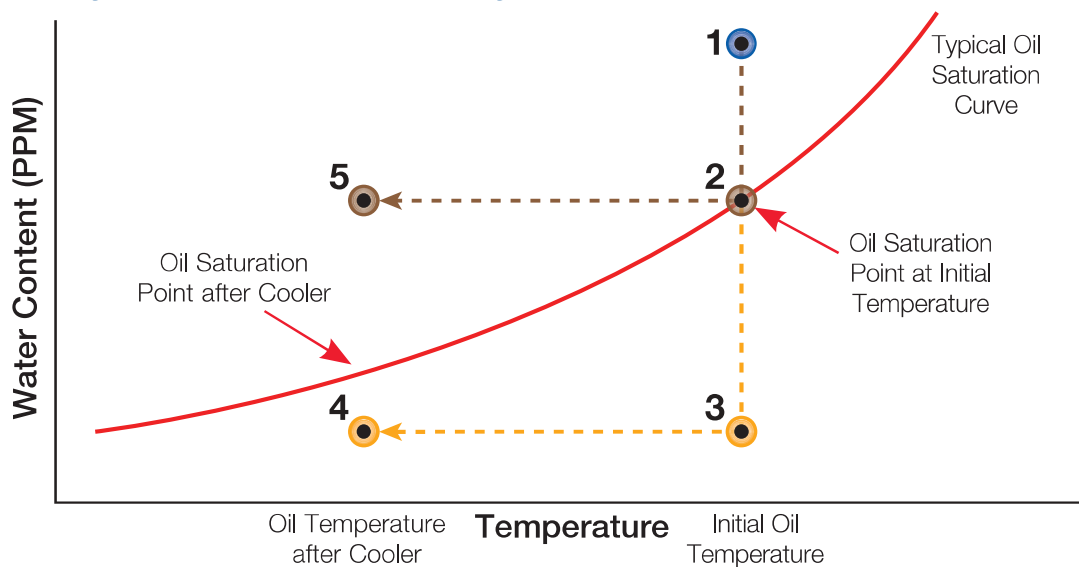

- 1 Initial water content is above saturation (free water).
- 2 Maximum water removal capability of “free water removal” devices (coalescers, centrifuges, etc.) is to the oil’s saturation point.
- 3 Water content achieved with mass transfer dehydration is significantly below the oil’s saturation point.
- 4 Water content achieved with mass transfer dehydration remains below the oil’s saturation point even after oil is cooled. This prevents the formation of harmful free water.
- 5 If only free water is removed at initial temperature, when oil is cooled the amount of harmful free water in the oil can increase significantly.

Pall Portable Oil Purifiers



Pall HLP6
HVP Series



Pall HNP022
HNP Series



Pall HNP075
HNP Series

Pall oil purifiers are available in a wide range of flowrates: from 10 L/min to 200 L/min (2.6 USgpm to 52.8 USgpm).

Contact Pall for special variants such as explosion proof, ATEX, or fully remote controlled purifiers

Oil Purifier Features

- Removes 100% free and up to 90% dissolved water
- Removes 100% free and up to 90% dissolved gases
- Unlimited water and air removal capacity
- Wide fluid compatibility
- Fully portable for multiple site application
- Simple to operate
- No heating required - does not burn oils
- Low power consumption
- Low operating costs
- Automatic control of the main operating parameters
- Robust and reliable under harsh conditions
- Easy maintenance

Typical Applications

- Hydraulic oils
- Lubrication oils
- Dielectric oils
- Phosphate-esters
- Quench oils

Lube and Hydraulic Filter Locations

Pressure Line

- To stop pump wear debris from travelling through the system
- To catch debris from a catastrophic pump failure and prevent secondary system damage
- To act as a Last Chance Filter (LCF) and protect components directly downstream of it

Return Line

- To capture debris from component wear or ingress travelling to the reservoir
- To promote general system cleanliness

Kidney loop/off-line

- To control system cleanliness when pressure line flow diminishes (i.e. compensating pumps)
- For systems where pressure or return filtration is impractical
- As a supplement to in-line filters to provide improved cleanliness control and filter service life in high dirt ingress systems

Reservoir Air Breather

- To prevent ingress of airborne particulate contamination
- To extend system filter element service life
- To maintain system cleanliness

Additional filters should be placed ahead of critical or sensitive components

- To protect against catastrophic machine failure (often non-bypass filters are used)
- To reduce wear
- To stabilize valve operation (prevents stiction)

Flushing Filter

- To remove particles that have been built-in to the system during assembly or maintenance before start-up
- To remove large particles that will cause catastrophic failures
- To extend 'in-service' filter element life

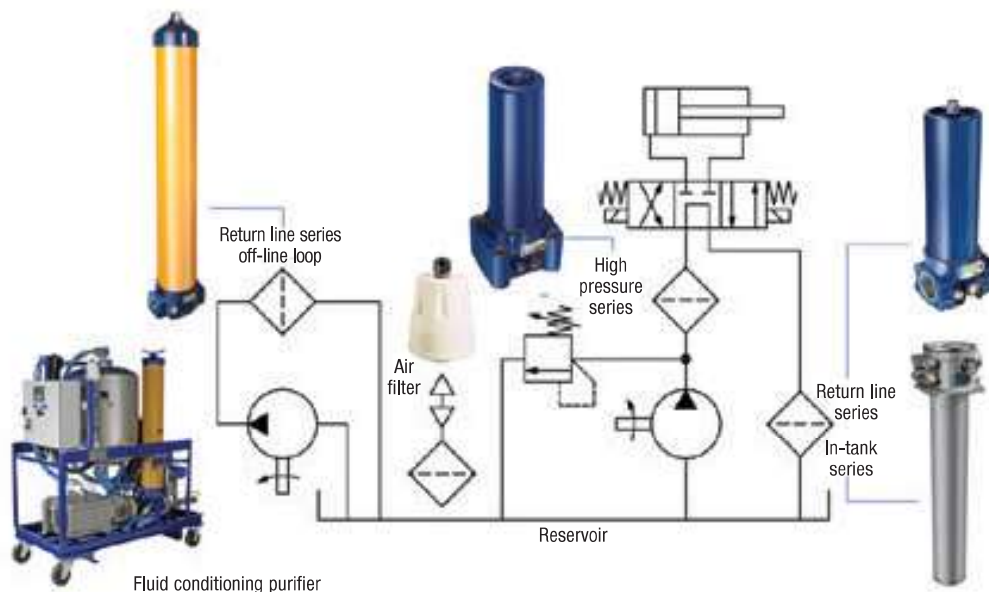

Pall Total Cleanliness Management (TCM) for Industrial Manufacturing

Enhancing Fluid Cleanliness, Advancing productivity, Assuring Reliability

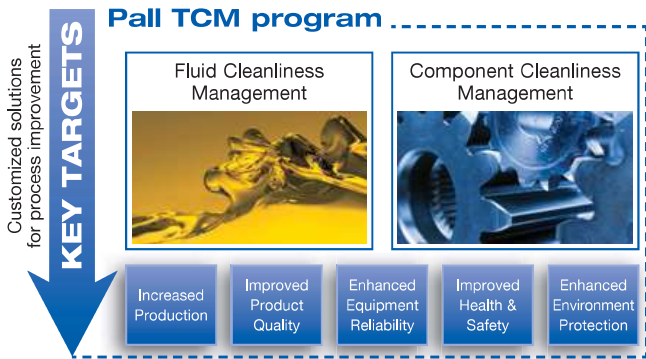

Pall provides customized contamination control solutions to improve system performance and reduce operating costs. Challenge us to deliver sustainable and cost-effective solutions to all your contamination problems.

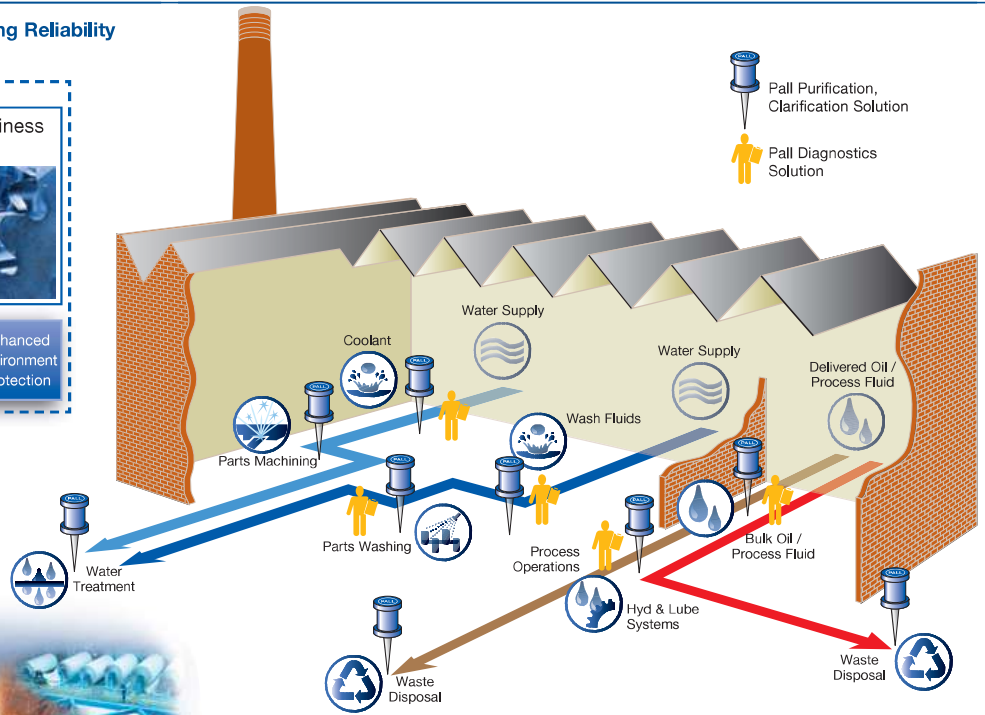

Examples of applications where the Pall TCM program can be implemented

Typical Fluids

- Parts washing fluids
- Coolants
- Lubrication oils
- Cutting fluids
- Water glycols
- Dielectric oils
- Process fluids
- Fuels
- Phosphate-esters
- Water
- Solvents
- Quench oils
- Hydraulic oils



**Better Lives.
Better Planet.™**

Short Element Life Checklist

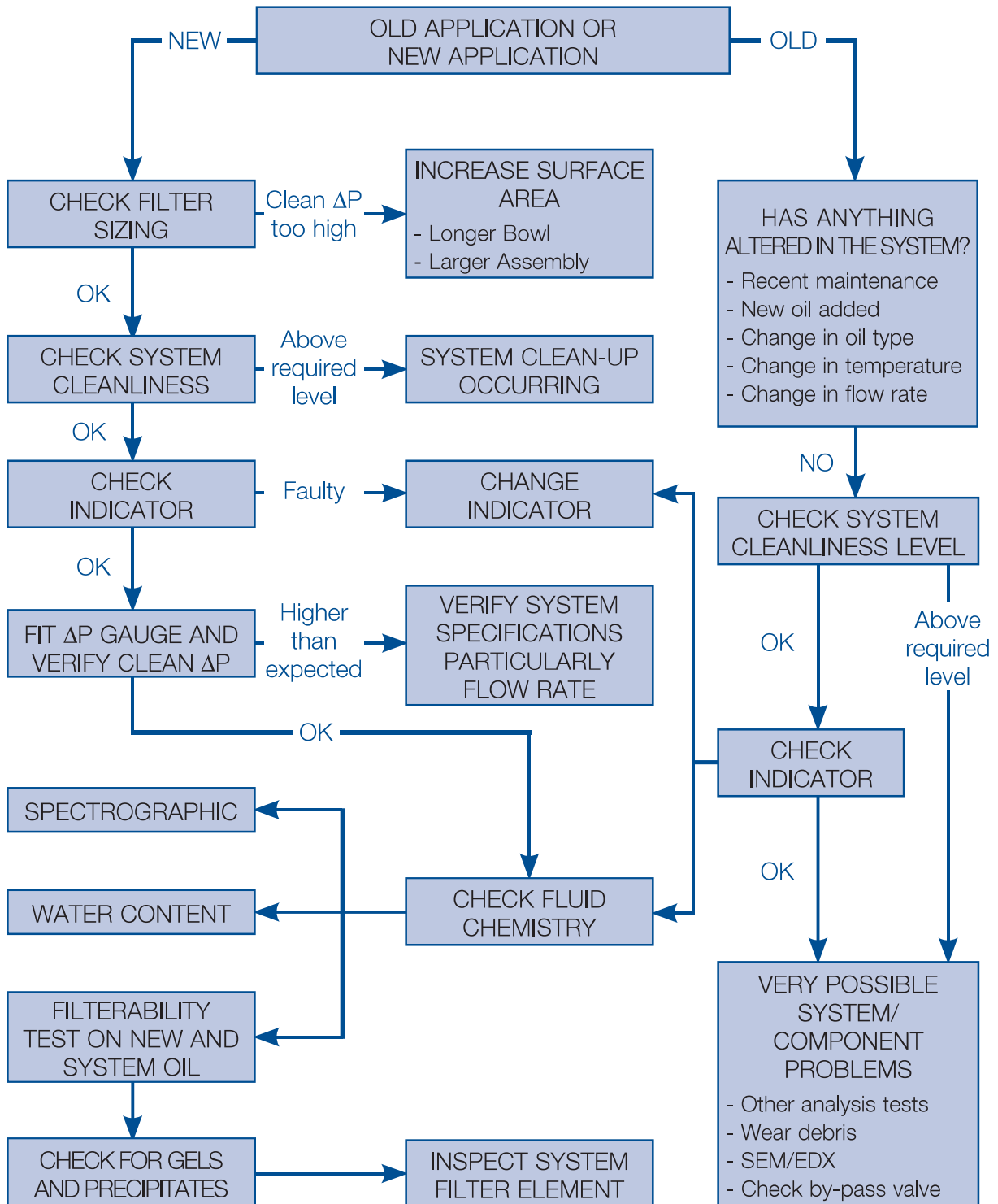

Flushing Recommendations

The aim of flushing is to remove contamination from the inside of pipes and components that are introduced during system assembly or maintenance. This is accomplished by passing clean fluid through the system, usually at a velocity higher than that during normal operation to pick up the particles from the surface and transport them to the flushing filter.

Omission or curtailment of flushing will inevitably lead to rapid wear of components, malfunction and breakdown.

Reynolds Number (Re): A non-dimensional number that provides a qualification of the degree of turbulence within a pipe or hose.

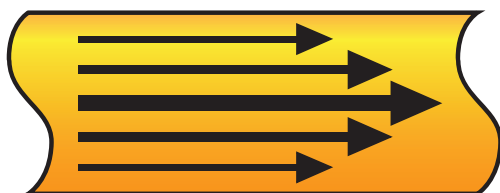

Laminar Flow



Turbulent Flow

Laminar Flow - $Re < 2,000$

Transitional Flow - $Re 2,000 - 4,000$

Turbulent Flow - $Re > 4,000$

For effective flushing procedures the Reynolds Number (Re) should be in excess of 4000

The flow condition in a pipe or hose can be assessed using Reynolds Number (Re) as follows:

$$Re = \frac{Ud}{\nu} \times 1,000$$

or

$$Re = 21,200 \times Q / (\nu \times d)$$

Re = Reynolds Number

U = Mean flow velocity (m/s)

d = Pipe internal diameter (mm)

ν = Kinematic viscosity of fluid in cSt (mm^2/s)

Q = Flow rate (L/min)

Filters for Hydraulic and Lubricating Fluids

Whatever your application in hydraulics or lubrication, Pall offers the most innovative filtration technology available to achieve the optimum cleanliness levels of your fluids.

Pall Filters Offer:

- Up to $\beta_{x(c)} \geq 2000$ removal efficiency
- Low, clean differential pressure
- Long service life
- Environmentally friendly coreless filter pack



Pall Filtration Milestones

- 1965 – Ultipor Filters
- 1966 – Ultipor Dirt Fuse Filters
- 1986 – Ultipor II Filters
- 1986 – Ultipor II Dirt Fuse Filters
- 1991 – Ultipor III Filters
- 1991 – Ultipor III Dirt Fuse Filters
- 1993 – Coreless Ultipor III Filters
- 2000 – Ultipor SRT Filters
- 2004 – Ultipleat SRT Filters
- 2014 – Coralon Filters
- 2014 – Coralon Dirt-Fuse Filters
- 2015 – Athalon Filters

A History of 'Industry Firsts'

- | | |
|---|------|
| • Glass fiber filter media | 1965 |
| • Fixed pore filter media | 1965 |
| • $\beta \geq 75$ filtration ratings | 1965 |
| • 3000 psid collapse-rated filters | 1966 |
| • Tapered pore filter structure | 1986 |
| • Polymeric drainage meshes | 1986 |
| • $\beta \geq 200$ filtration ratings | 1986 |
| • Helical outer wrap | 1990 |
| • Coreless/cageless construction | 1993 |
| • $\beta \geq 1000$ filtration ratings | 1999 |
| • Stress-resistant filter medium | 2000 |
| • ISO Code (CST) filtration ratings | 2004 |
| • Laid-over pleating | 2004 |
| • Triboelectric charge-resistance | 2004 |
| • In-to-out flow path | 2004 |
| • Life-extending drainage meshes | 2009 |
| • $\beta_{x(c)} \geq 2000$ filtration ratings | 2015 |

Athalon™

The Ultimate in Filter Performance

Stress resistant technology, $\beta_{x(c)} \geq 2000$ ratings, anti-static construction. Keep fluids cleanest, longest, for the greatest value

Coralon Filters

Advanced Equipment Protection

Stress resistant technology, $\beta_{x(c)} \geq 1000$ ratings.

Coralon™ Filters - Advanced equipment protection

New Coralon™ filters are a direct upgrade (same form, fit, and function including fluid and temperature compatibility) for current Ultipor™ filter elements. They represent a significant advancement in equipment protection for existing users.

Coralon Filters

Keep fluids cleaner, longer, for greater value

Features

- Advanced pack design incorporating Stress-Resistant media Technology (SRT)
- Low clean element pressure drop for longer life
- Optimum performance under system stresses at all stages of filter life for consistently cleaner fluid
- Out-to-in flow path
- Fan pleat configuration



Filter element hardware available with either corrosion protected carbon steel endcaps and core (as shown) or polymer endcaps for Ultipor III Coreless housing designs

Benefit: Comprehensive upgrade range, environmentally friendly designs for reduced disposal costs and ease of element changeout.

SRT Media pack* for increased resistance to system stresses such as cyclic flow and dirt loading

Benefit: Improved performance over the life of the filter for more consistent fluid cleanliness

Pall Housing & Pall Ultipor® III Element



Upgraded filtration for improved protection and reduced costs...

Pall Coralon Filtration

- Improved fluid cleanliness
- Consistent performance throughout filter service life
- Lower pressure drop
- Same housing

✓...same price!

- ✓ 15x improvement in fluid cleanliness
 - ✓ 16x improvement in fluid cleanliness stability (throughout the filter's service life)
 - ✓ Up to 20% reduction in total cost of filtration
- Leading to reduced equipment operating costs

The Ultimate in Filter Performance

Pall's Athalon™ hydraulic and lube oil filters combine Beta_{x(c)} ≥ 2000 rated, stress-resistant filter technology and a full range of housings to provide the greatest overall filter performance and value available in industry today.

- Laid Over Pleat (LOP) Filter Media Geometry
- Stress-Resistant Filter Medium
- Anti-Static Construction
- Coreless/Cageless Construction
- Simple to Install and Inexpensive to Maintain

Athalon™

'Setting new standards in filter element design'

Beta_{x(c)} ≥ 2000 rated Stress Resistant media Technology in a Laid-Over Pleat configuration: Inert, inorganic fibers securely bonded in a fixed, tapered pore structure with increased resistance to system stresses such as cyclic flow and dirt loading.

High pressure, return line and intank Athalon filter housing designs

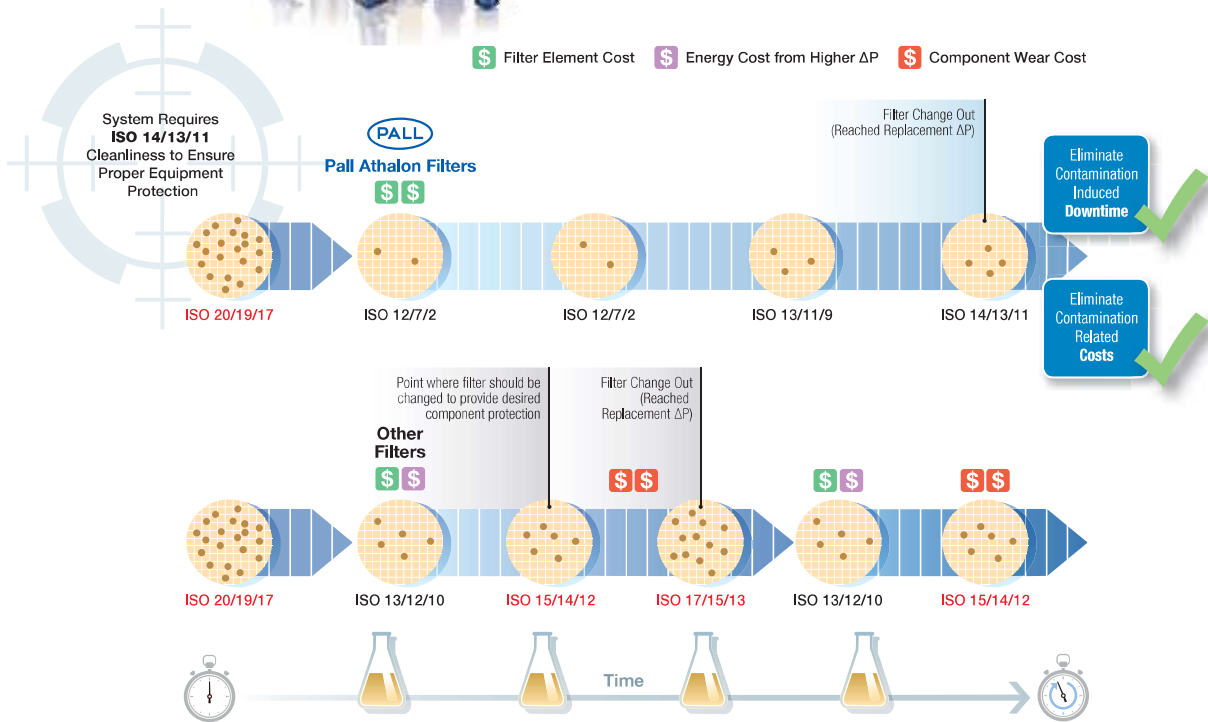

Keeping Fluids the Cleanest, Longest, for the Greatest Value.

At no time can you assess the fluid condition with the naked eye. All bottle samples look the same.

Advanced Test Method for Measuring Filter Performance

Cyclic Stabilization Test*

Schematic

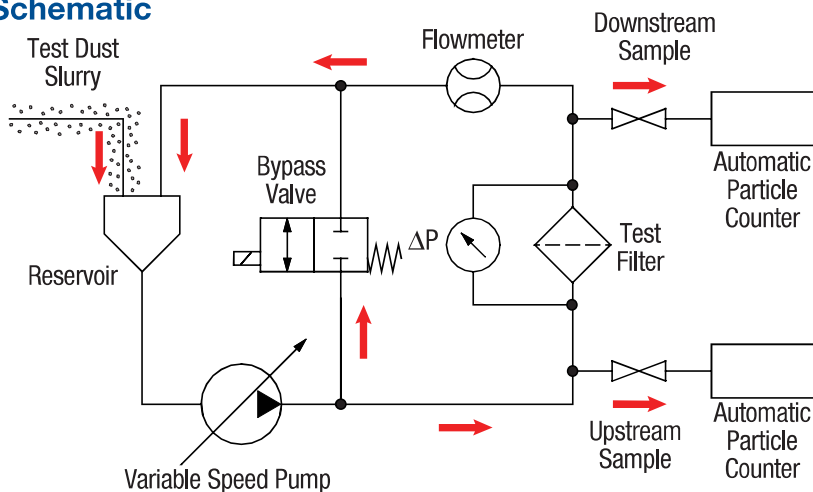

Cyclic Stabilization Test (CST) measures a filter's ability to clean up a contaminated system under cyclic flow (25 to 100% of rated flow) and contaminant loading conditions

*based on SAE ARP4205

Concept:

As opposed to ISO 16889 that only tests filters under steady state conditions, the Cyclic Stabilization test is used to evaluate hydraulic filter performance under typical stressful operating cyclic conditions such as:

- Flow surges
- Pressure peaks
- Cold starts

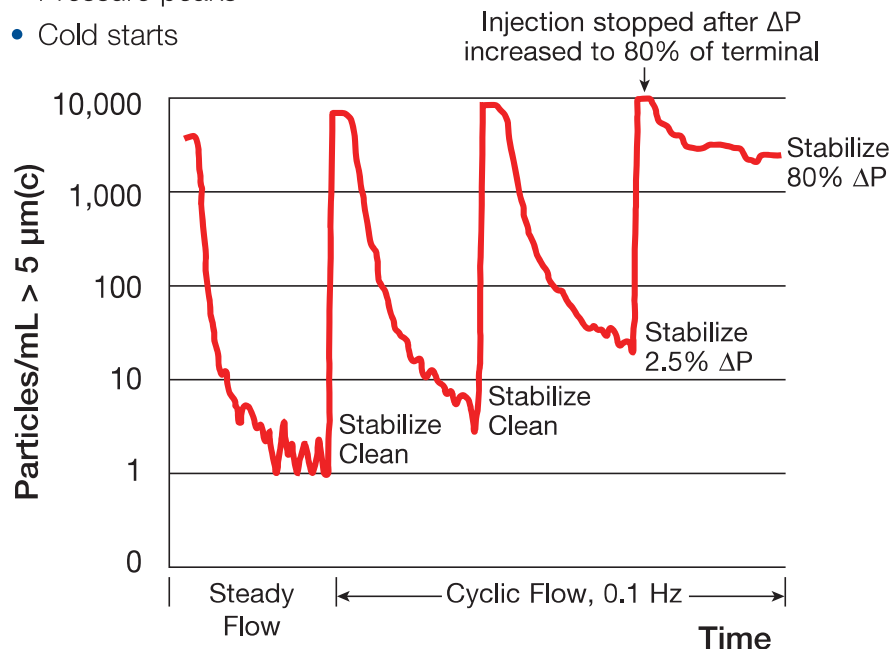

CST ISO 4406 Cleanliness Code ratings are based on the stabilized cleanliness achieved at 80% of the net terminal pressure drop, considered the worst operating condition

For clarity, only the number of particles/mL >5μm(c) are shown

Pall Athalon™ Filter Performance Data

Athalon Grade	$\beta_{x(c) \geq 2000}$ per ISO 16889	Cleanliness Code Rating (ISO 4406) from Cyclic Stabilization Test*
AZ	3	07/04/01
AP	5	11/08/03
AN	7	13/09/04
AS	12	15/11/06
AT	25	16/14/08

* CST: Cyclic Stabilization Test to determine filter rating under stress conditions, based on SAE ARP4205
 Note these ISO codes are laboratory measurements under standard conditions. Cleanliness measured in actual operation will depend on operating conditions and sampling method.

Multi-Pass Filter Ratings (ISO 16889)

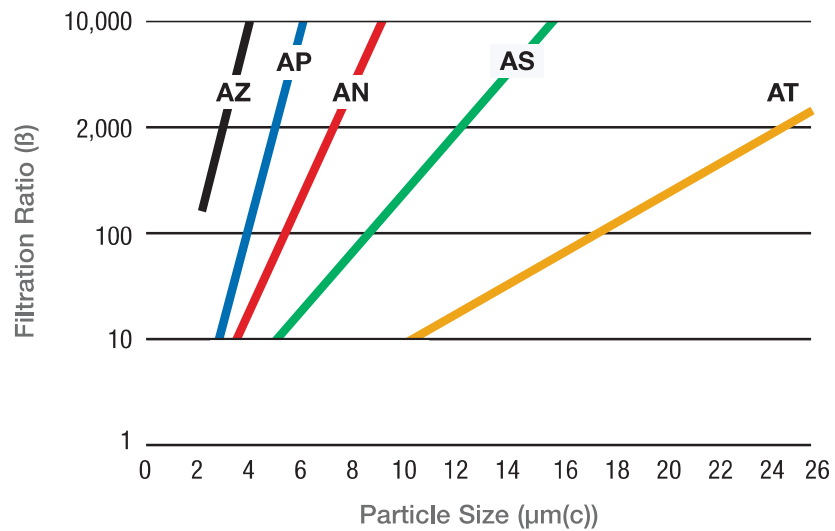

Traditional Fan-Pleat Filter

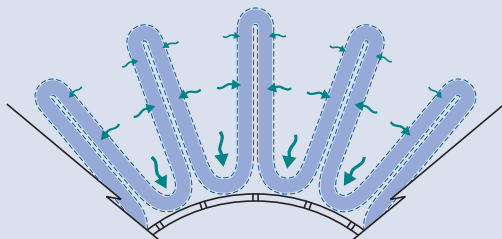

Pall Athalon Filter

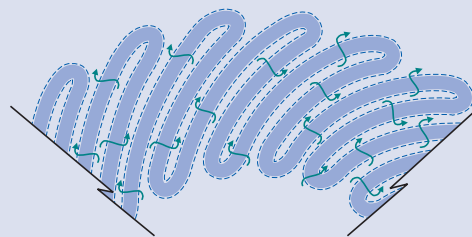

The optimized pleat geometry of SRT filtration provides:

- Uniform flow distribution and increased flow capacity
- Maximum filter surface area and element life

Triboelectric Charging Effect on Filtration

Triboelectric Charging Resistant (TCR) Filters

- Designed to dissipate triboelectric charge build-up
- Produce only minimal triboelectric charging of the fluid (as measured by the fluid charge)
- Minimize fluid degradation and varnish formation

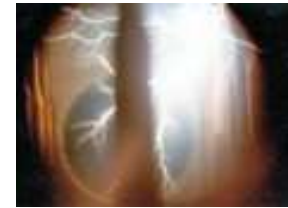

Electrical discharge occurring inside oil tank

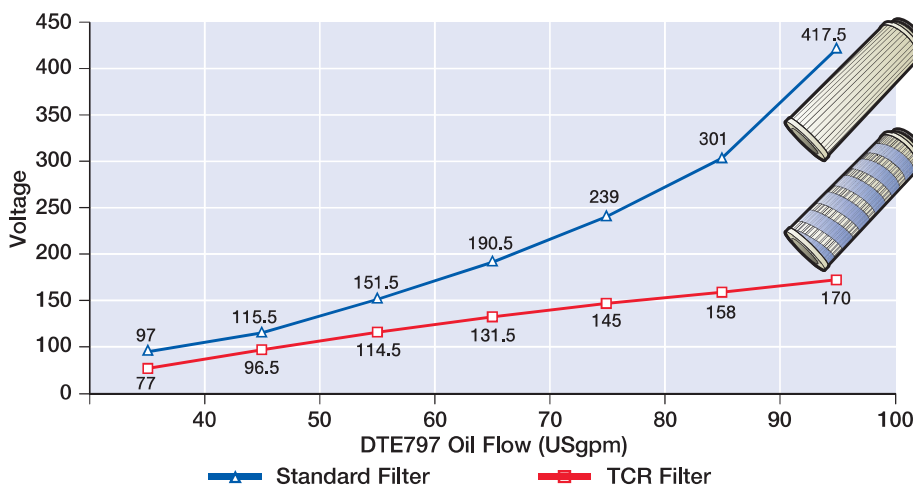

Filtration and Contamination Standards

ISO 2941	Filter elements - Verification of collapse/burst pressure rating
ISO 3968	Filters - Evaluation of differential pressure versus flow characteristics
ISO 4021	Extraction of fluid samples from lines of an operating system
ISO 4407	Determination of particulate contamination by the counting method using an optical microscope
ISO 11171	Calibration of automatic particle counters for liquids
ISO 16889	Filter elements - Multi-pass method for evaluating filtration performance of a filter element
ISO 18413	Component cleanliness - Inspection document and principles related to contaminant collection, analysis and data reporting
ISO 21018-3	Monitoring the level of particulate contamination of the fluid - Part 3: Use of the filter blockage technique
SAE ARP4205	Filter elements - Method for evaluating dynamic efficiency with cyclic flow

Note: This is a small selection of ISO standards relevant to hydraulic and lubrication applications.

Differential Pressure Indicators and Switches

Differential pressure (ΔP) indicators and switches notify the operator of the filter condition. This allows a replacement filter to be installed before filter element bypass occurs.

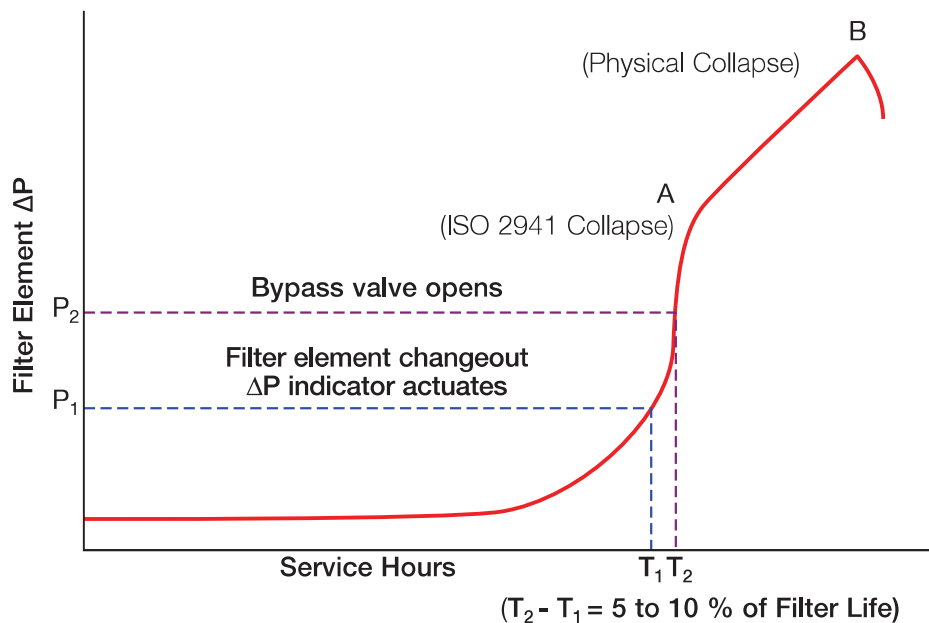

ΔP across the filter increases as contaminant is trapped within the filtration medium. A ΔP indicator actuates at P_1 , signalling the need for element change before the bypass relief valve opens at P_2 . The bypass valve protects the filter and system from excessive differential pressure.

Without a bypass valve, continued operation at higher ΔP risks degradation of filtration performance (point A) and filter element collapse (point B) where the integrity of the filter element is lost.

Differential Pressure Indicators and Switches

Mechanical and Electrical Options Available

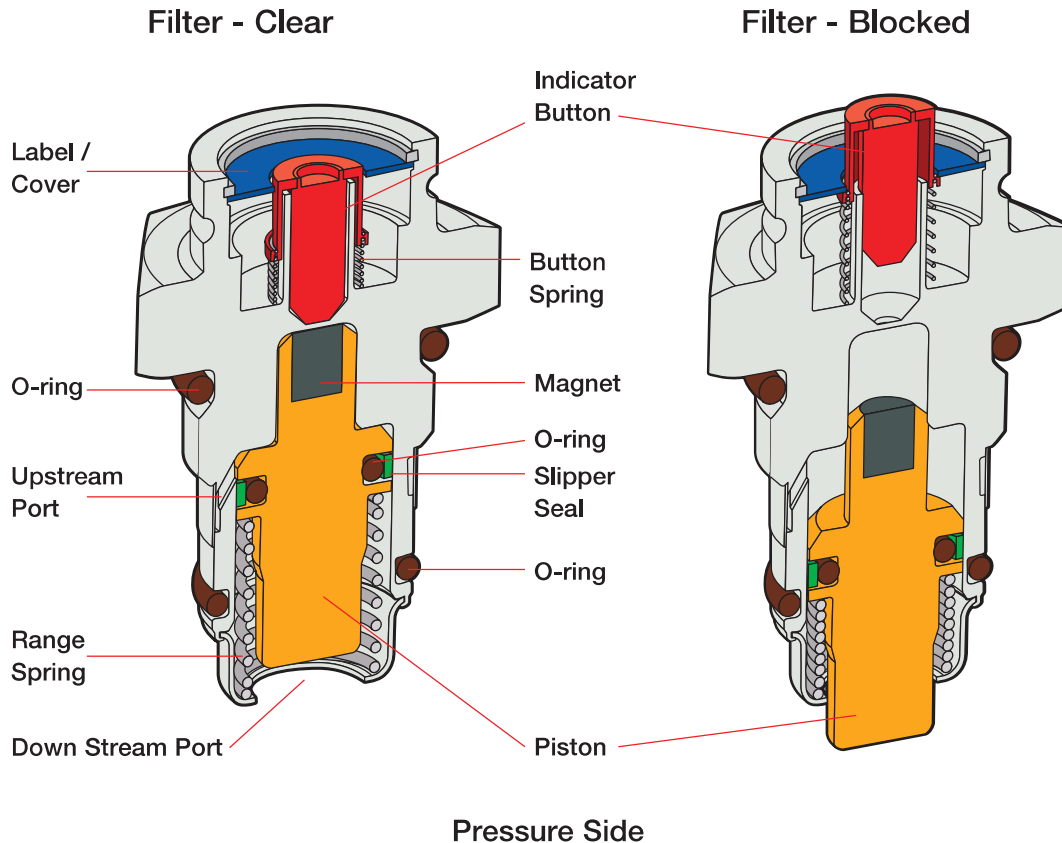

Technical principle of the mechanical indicators:

Differential pressure indicators operate by sensing the ΔP between ports upstream and downstream of the filter element. When the ΔP across the internal piston/magnet assembly reaches a preset value, determined by the range spring, the piston assembly moves downward, reducing the attractive force between the magnet and indicator button. The indicator button spring then overcomes the reduced magnetic force and releases the button to signal the need for element change. Activation can be visual using a button as shown here or electrical using a microswitch.

A variety of differential pressure indicator models are available. Contact Pall to determine the most appropriate ΔP indicators or switches for your applications.

Filters for Process Fluids



Recommended for industrial applications to treat water, fuels, aqueous solutions, and low viscosity process fluids.

Recognizing that different applications have different fluid cleanliness and filtration requirements, the Pall range of Melt Blown filter products is simply defined to help you choose the best solution at the most economic cost.

Highly Critical Cleanliness

For applications such as fluid make-up, cleanliness control, polishing or clarification, where the full range of solid contamination removal including silt is required.

Critical to General Particulate Control

Cleanliness control in wash applications, machining applications where high surface finish is required, single pass in-line last chance filtration applications, and for general purpose fluid clarification.

General Particulate Control

Coarser ratings for primary or pre-filtration applications, or higher fluid flow applications where a fluid cleanliness level is not specified.

Particulate Control	Efficiency Rating%	Recommended Range (µm)
Highly Critical	99.98%	1, 3, 6, 12, 20
Critical to General	99.9%	40, 70, 90
General	90%	100, 150, 200



Different medium configurations can be applied to specific user requirements. The Pall filter element range is available in -

- 1 Depth
- 2 Fan pleated
- 3 Patented laid over pleat (Ultipleat®) designs.

Applications

- Component wash fluids
- Cutting fluids
- Process fluids
- Water
- Coolants
- Water glycols
- Mineral and synthetic oils
- Lubricants
- Fuels
- Solvents

Separation Systems for Process Fluids

Crossflow Filtration Systems

Pall Clarisep crossflow filtration systems remove tramp oil, suspended solids and bacteria from water-based fluids to maintain the fluid in optimum condition for extended service life. These systems can also be used to process oily wastewater, minimizing the volumes that have to be disposed of off-site.

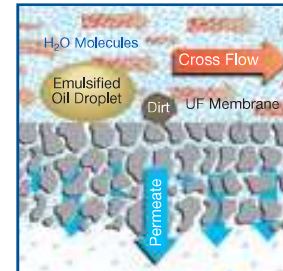

Pall Clarisep Membrane

Pall crossflow systems direct fluid flow across the surface of a porous membrane. Emulsified oil and grease, bacteria, fungi and suspended solids are larger than the membrane pores and are, therefore, held back, allowing clean fluid to pass downstream.

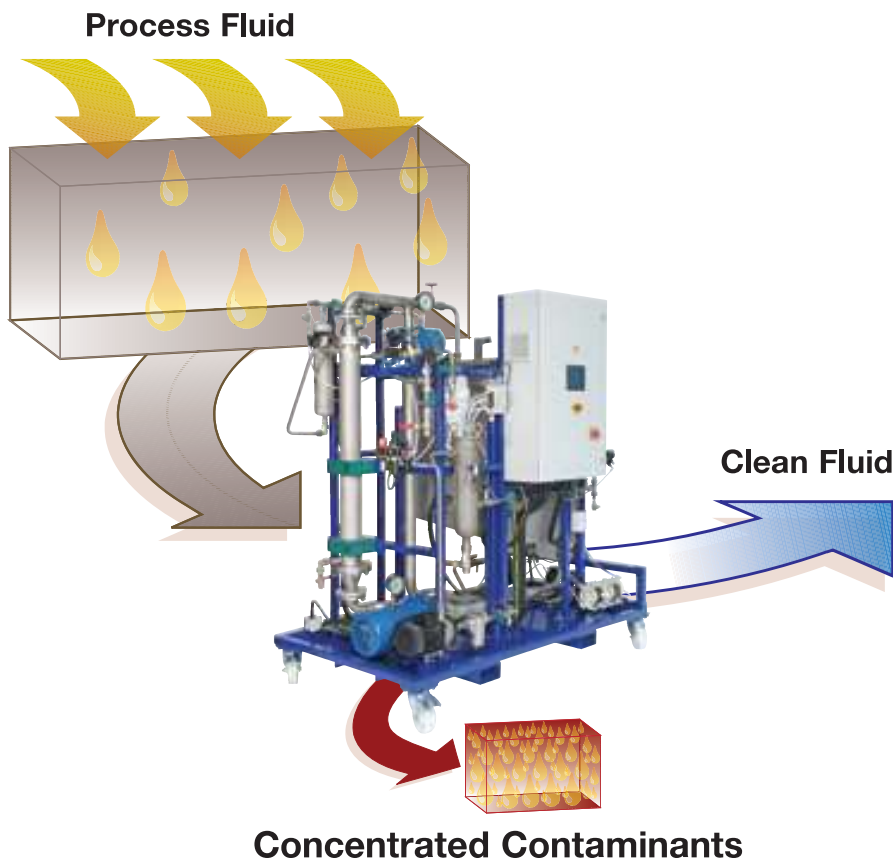

Pall offers a range of membrane technologies, allowing the optimum solution to be selected for a specific application. All Pall Clarisep systems automatically regenerate in-situ for extended life.

Diesel Fuel Purification

Diesel Engine Fuel Cleanliness Control - From delivery, to storage, to pump, to injector

The latest injection technology for diesel powered engines requires superclean fuels. Fine filtration and liquid/liquid coalescence are strategically required along the diesel supply chain.

Example of a Basic Mining Fuel Distribution System

Fuel Delivery

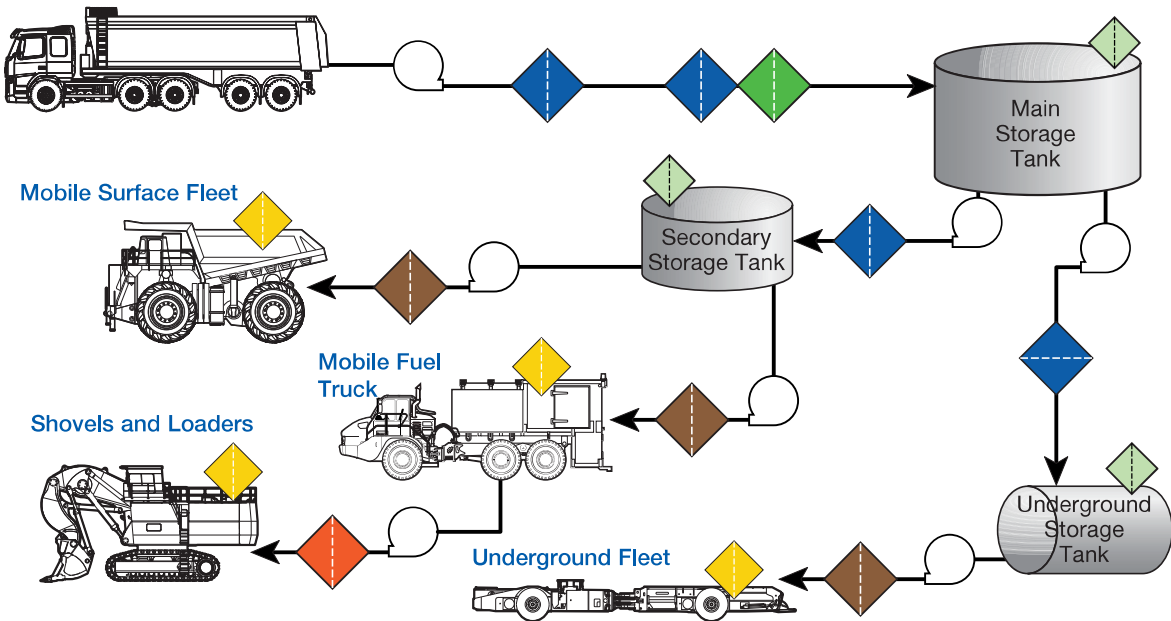

Bulk Diesel
Fuel Filtration

Liquid/Liquid
coalescer

Point of use
fuel filter

Mobile support
fuel filter

On board
fuel filter

Air breather
filter



Pall Ultipleat® Diesel Plus
Fuel Filter Elements



Pall Athalon™
Filter Elements



Pall Ultipleat® Diesel
Fuel Filter Elements

Component Cleanliness Management

Component Cleanliness Management (CCM) is a comprehensive program designed to help clients achieve desired component cleanliness. After working with you to validate processes and set cleanliness specifications, the program follows a defined path to assess component cleanliness and identify areas for improvement. We then provide recommendations and assist in their implementation

**Design it
Build it
Keep it** **CLEAN**



PCCM Cleanliness Cabinet

Pall Cleanliness Cabinets

Pall Component Cleanliness Cabinets facilitate the accurate, reliable and repeatable determination of component cleanliness.

- Stainless steel construction
- Controlled extraction environment
- Automated cleaning to “blank” values
- Pressurized solvent dispensing and recycling circuits
- Meet ISO 18413, ISO 16232 and VDA 19 procedures
- Available in small, medium or large cabinet options

Required Fluid Cleanliness Level Worksheet*

Selection of the appropriate cleanliness level should be based upon careful consideration of the operational and environmental conditions. By working through this list of individual parameters, a total weighting can be obtained from the graph on page 39, to give the Required Cleanliness Level (RCL).

Table 1. Operating Pressure and Duty Cycle

Duty	Examples	Operating Pressure (bar (psi))					Actual
		0-70 (0-1000)	>70-170 (>1000-2500)	>170-275 (>2500-4000)	>275-410 (>4000-6000)	>410 (>6000)	
Light	Steady duty	1	1	2	3	4	
Medium	Moderate pressure variations	2	3	4	5	6	
Heavy	Zero to full pressure	3	4	5	6	7	
Severe	Zero to full pressure with high frequency transients	4	5	6	7	8	

Table 2. Component Sensitivity

Sensitivity	Examples	Weighting	Actual
Minimal	Ram pumps	1	
Below average	Low performance gear pumps, manual valves, poppet valves	2	
Average	Vane pumps, spool valves, high performance gear pumps	3	
Above average	Piston pumps, proportional valves	4	
High	Servo valves, high pressure proportional valves	6	
Very high	High performance servo valves	8	

Table 3. Equipment Life Expectancy

Life Expectancy (hours)	Weighting	Actual
0-1,000	0	
1,000-5,000	1	
5,000-10,000	2	
10,000-20,000	3	
20,000-40,000	4	
>40,000	5	

Table 4. Component Replacement Cost

Replacement Cost	Examples	Weighting	Actual
Low	Manifold mounted valves, inexpensive pumps	1	
Average	Line mounted valves and modular valves	2	
High	Cylinders, proportional valves	3	
Very high	Large piston pumps, hydrostatic transmission motors, high performance servo components	4	

Table 5. Equipment Downtime Cost

Downtime Cost	Examples	Weighting	Actual
Low	Equipment not critical to production or operation	1	
Average	Small to medium production plant	2	
High	High volume production plant	4	
Very high	Very expensive downtime cost	6	

Table 6. Safety Liability

Safety Liability	Examples	Weighting	Actual
Low	No liability	1	
Average	Failure may cause hazard	3	
High	Failure may cause injury	6	

* Adapted from BFFA/P5 Target Cleanliness Level Selector 1999 Issue 3.

Table 7. System Requirement

Cleanliness Requirement Total Weighting	Total
Sum of 'Actual' weighting from sections 1 through 6	

Using the chart below, determine where the 'Cleanliness Requirement Total Weighting' number from Table 7 intersects the red line. Follow across to the **left** to find the recommended ISO 4406 Code.

Table 8. Environmental Weighting

Environment	Examples	Weighting		Actual
		Single Filter	Multiple Filters*	
Good	Clean areas, few ingress points, filtered fluid filling, air breathers	0	-1	
Fair	General machine shops, some control over ingress points	1	0	
Poor	Minimal control over operating environment and ingress points e.g. on-highway mobile equipment)	3	2	
Hostile	Potentially high ingress (e.g. foundries, concrete mfg., component test rigs, off-highway mobile equipment)	5	4	

* Single filter or multiple filters with the same media grade on the system.

Table 9. Required Filtration Level

Filtration Requirement Total Weighting	Total
Add Environmental Weighting (Table 8) to System Requirement Total (Table 7)	

Using the chart below, determine where the 'Required Filtration Level' total in Table 9 intersects the red line. Follow across to the **right** to find the corresponding recommended Pall filter grade.



†Using on-line particle counting

Common Fluid Power Circuit Diagram Symbols

ISO1219-1: Fluid power systems and components - Graphic symbols and circuit diagrams - Part 1: Graphic symbols for conventional use and data processing applications.

Cylinders and Semi-rotary Actuators

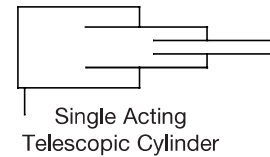
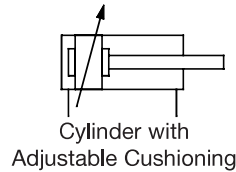
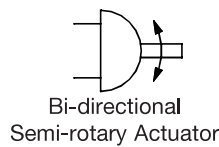
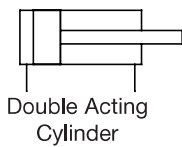

Pumps and Motors

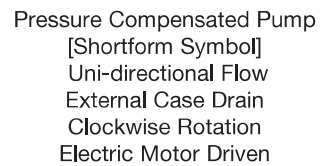
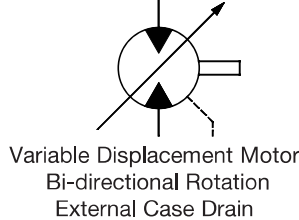
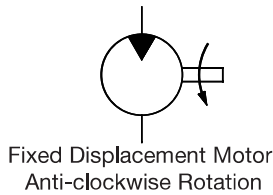
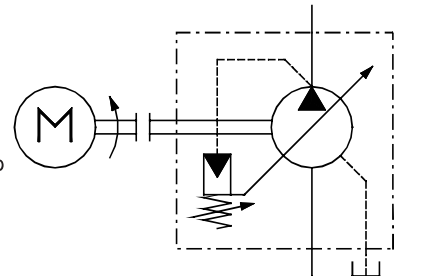
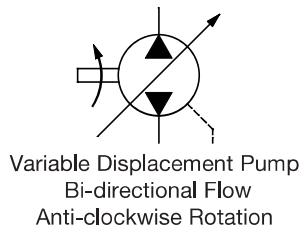
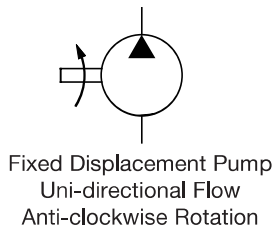

Directional Control Valves (Unspecified Actuation)

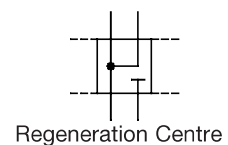
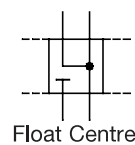
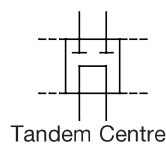
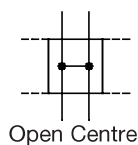
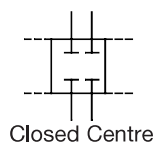
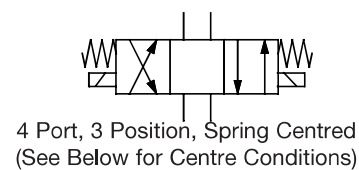
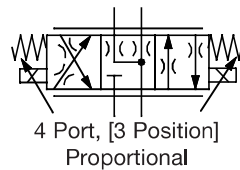
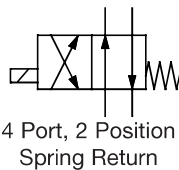
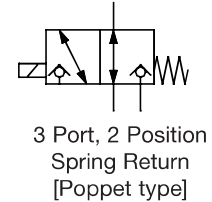
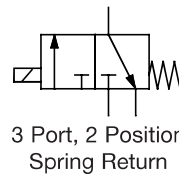
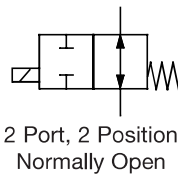
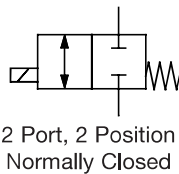

Directional Control Valve Actuation



Pressure Control Valves

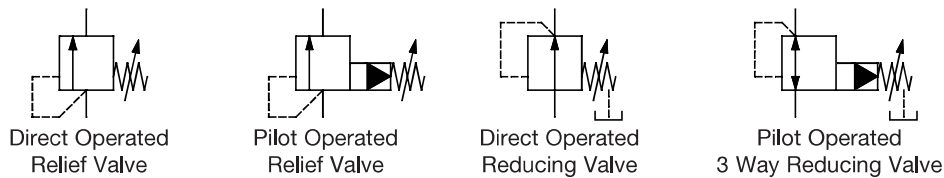

Isolation and Flow Control Valves

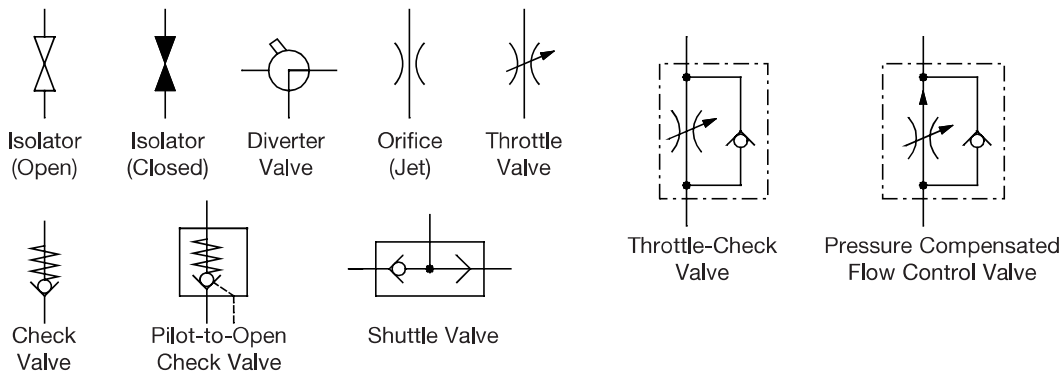

Filters and Coolers

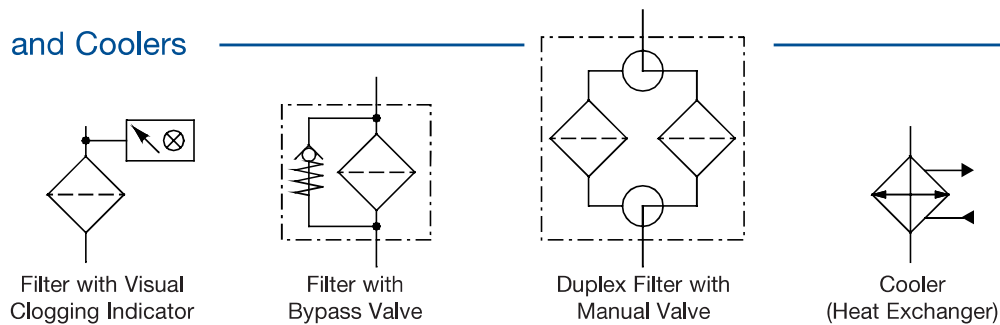

Instrumentation and Pipeline Components

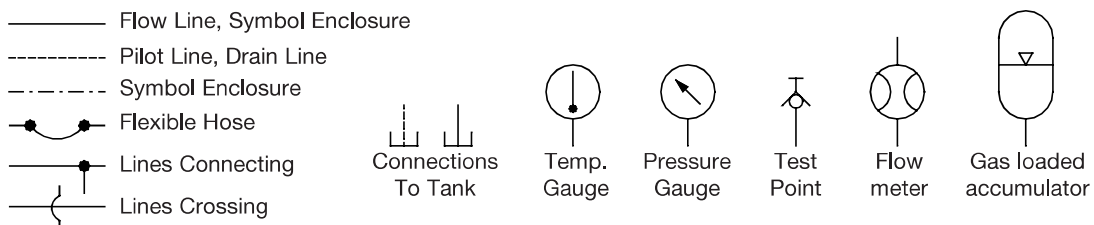



**Better Lives.
Better Planet.SM**



Pall Corporation

25 Harbor Park Drive
Port Washington, NY 11050
+1 516 484 3600 telephone
+1 800 289 7255 toll free US

Portsmouth-UK
+44 (0) 9233 8000 telephone
+44 (0) 9233 8811 fax
industrial@pall.com



Visit us on the Web at www.pall.com

Pall Corporation has offices and plants throughout the world. For Pall representatives in your area, please go to www.pall.com/contact

Because of technological developments related to the products, systems, and/or services described herein, the data and procedures are subject to change without notice. Please consult your Pall representative or visit www.pall.com to verify that this information remains valid.

© Copyright 2016, Pall Corporation. Pall, , Athalon, Phasesep, Ultipor, Ultipleat and Coralon are trademarks of Pall Corporation.
® indicates a trademark registered in the USA.
BETTER LIVES, BETTER PLANET and Filtration. Separation. Solution.SM are service marks of Pall Corporation.